



# TECHNICAL IMPROVEMENT BULLETIN

TIB001-072110

 **ATRO** is an ISO 9001 Registered Manufacturer of Polyurethane Components for the Heavy-Duty Suspension Industry

## ATRO Part Number: TR59-41474

**Description:** Torque Rod

**Cross-references:** Kenworth#: K195-474 (Aluminum)

**Application:** Kenworth Airglide 200/400/460/690

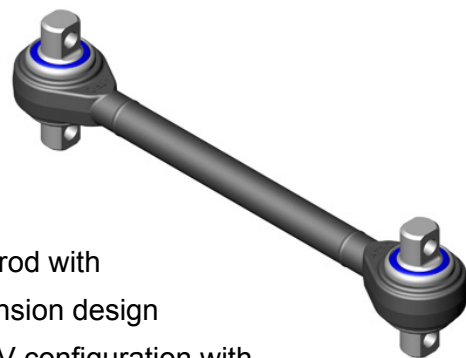

The TR59-41474 Torque Rod was designed specifically for the Kenworth Airglide suspension and replaces the original aluminum rod with a stronger, more durable alternative. The Kenworth Airglide suspension design combines the transverse and tracking torque rods into a dual rod, V configuration with the torque rods mounted vertically. This design requires an extreme amount conical motion from the bushings due to the torque rods being mounted vertically instead of the more familiar horizontal arrangement. This mounting configuration places much more bending stress on the rod. To handle this additional stress the improved ATRO rod features forged steel rod eyes and a heavy-walled steel shaft. Additional conical movement was also added by equipping our rods for this application with the new ATRO TS59-22400 High Articulation Bushing. While this bushing does not have the trademark ATRO rotating feature which has made our standard torque rod bushings so popular in the heavy duty trucking industry, it does utilize articulation voids and a modified pin to provide the extra vertical motion required by this very demanding application.

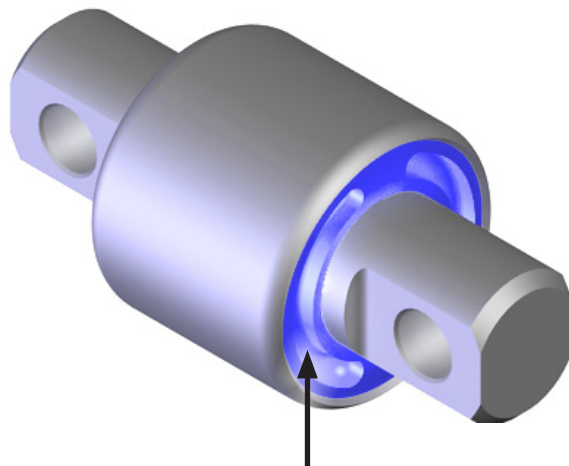

Articulation Void



1250 Airport Road, Sullivan, Missouri 63080  
(573) 860-8400 • (800) 325-6114 toll-free • Fax: (573) 860-8401  
[www.atrobushing.com](http://www.atrobushing.com) • e-mail [sales@atrobushing.com](mailto:sales@atrobushing.com)

©2010 ATRO ENGINEERED SYSTEMS, INC.

ATRO is not liable for any errors herein. All manufacturers' names and part numbers used are trademarked by the respective manufacturer. These names and part numbers are being used without permission. No endorsement, affiliation or recommendation is implied. They are included for reference purposes only.  
Some products shown here are covered by Canadian Patent 1,327,979; Australian Patent 630,358.

TIB001-072110