

INSTALLATION INSTRUCTIONS

VOLVO T-RIDE V-ROD APEX BUSHING (ATRO PART NUMBER TH96-22200)

1) Bushing Removal

- Remove steel cap from rod eye by either grinding off the tack welds (older style) or prying off (newer, crimped style).



Remove Steel Cap

Remove Grease Boot

- Remove the center bolt holding the plate on.

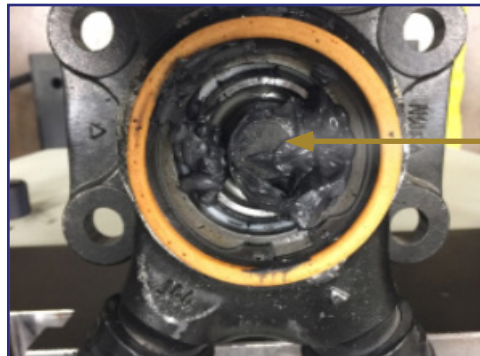

Remove Bolt

- Remove grease boot from bottom of apex rod eye.
- Thread an M20x1.5 bolt into the old apex bushing pivot ball until it bottoms against the top of the plates' taper stud. Continue tightening the bolt until the plate separates from the pivot ball.



Tighten bolt to separate plate from apex bushing

- CONTINUED -

INSTALLATION INSTRUCTIONS

ATRO PARTS

ENGINEERED | DURABLE | RELIABLE
MANUFACTURED IN ST. CLAIR, MISSOURI | U.S.A.

VOLVO T-RIDE V-ROD APEX BUSHING (ATRO PART NUMBER TH96-22200)

-CONTINUED-

- Remove the retaining ring, steel retaining washer, and plastic wedge washer from the rod eye.
- Using the small end of the ATRO PT96-52300 tool, or a piece of tube/bar with the correct OD (approximately 2 3/16"), press the old apex bushing out.



2) Bushing Installation

- Thoroughly clean inside of rod eye – remove any excess rust or debris.
- Using a file or alternate method, remove any burrs and sharp edges from leading edge of rod eye.
- Lubricate ID of rod eye and OD of TH96-22200 apex bushing with P-80, grease, or other lubricant.
- Using ATRO install tool PT96-52300, press the new ATRO TH96-22200 apex bushing into rod eye until fully seated. A piece of tubing or large socket with an OD of 2 13/16" and an ID of 2 1/4" may be used as an alternative to the PT96-52300 tool.

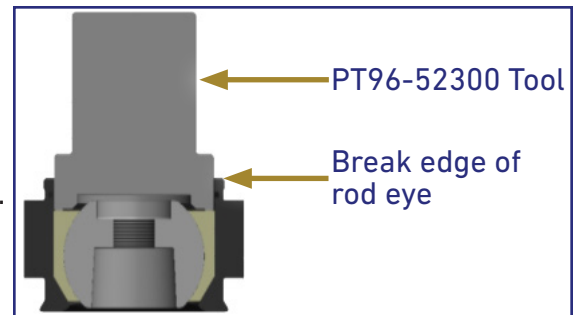

- Insert the supplied steel retaining washer on top of the apex bushing.
- Install the supplied new retaining ring.
- Clean any corrosion or contamination from the mount plate taper stud.
- Insert mount plate taper stud into apex bushing.
- Apply medium strength threadlocker to the bolt included with the ATRO apex bushing kit and thread into the taper stud. Torque bolt to 100 ft-lb.
- Install metal dust cover onto top of V-Rod and stake in place using a punch or similar tool.

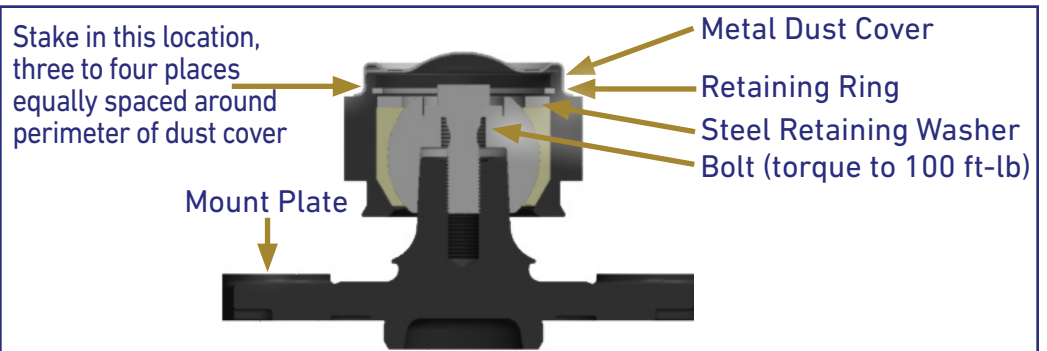

CELEBRATING 30 YEARS
ATRO
POLYURETHANE • SOLUTIONS

POLYURETHANE PARTS | SOLUTIONS FOR HEAVY TRUCKS

ATROBUSHING.COM
©2018 ATRO ENGINEERED SYSTEMS, INC.

6 Bolte Lane
St. Clair, Missouri 63077 | U.S.A.
(800) 325.6114 | Fax (866) 920.2005